



Low voltage AC drives

# ABB industrial drives

## ACS880-01, single drives

### 0.55 to 250 kW

### Catalog

# What does all-compatible mean for you?

Being all-compatible means that drive choice should add value to your business. Drives should meet the unique demands of your processes, help you save energy and reduce operating costs. Also, all-compatible means that our drives are easy to select, use and maintain. These are the cornerstones making our industrial drive series the all-compatible choice.

## Contents

|    |  |
|----|--|
| 3  | The all-compatible ACS880 series drives                            |
| 4  | Designed to help you make your process more efficient and reliable |
| 6  | Human all-compatible   |
| 7  | Process all-compatible   |
| 8  | Environment all-compatible   |
| 9  | Business all-compatible  |
| 10 | How to select a drive  |
| 10 | Technical data   |
| 11 | Ratings, types and voltages  |
| 12 | Standard interface and extensions for comprehensive connectivity   |
| 13 | Standard software for scalable control and functionality           |
| 14 | Intuitive human-machine interface                                  |
| 15 | PC tool for easy startup and maintenance                           |
| 16 | Integrated safety for simplified configuration                     |
| 17 | Flexible connectivity to automation networks                       |
| 18 | Input/output extension modules for increased connectivity          |
| 18 | Speed feedback interfaces for precise process control              |
| 18 | Brake options  |
| 19 | EMC – electromagnetic compatibility                                |
| 20 | du/dt filters  |
| 22 | Expertise at every stage of the value chain                        |
| 23 | Secure uptime throughout the drive life cycle                      |

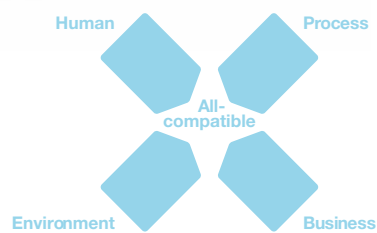

## The all-compatible ACS880 series drives

The ACS880 series drives are part of ABB's all-compatible drives portfolio. Compatible with virtually all types of processes, automation systems, users and business requirements they are designed to tackle any motor-driven application, in any industry, whatever the power range. The innovation behind all-compatibility is our new drives architecture that simplifies operation, optimizes energy efficiency and helps maximize process output. The ACS880 series consists of single drives, multidrives and drive modules.

# Simplifying your world without limiting your possibilities.

## Wide range of safety features

Safe torque-off is built in as standard. An optional safety functions module provides extended safety functions, simplifying the configuration and reducing installation space.



## Direct torque control (DTC)

ABB's signature motor control technology provides precise speed and torque control for all applications and virtually any type of AC motor.

## Removable memory unit

Stores all the software and parameter configurations in an easily replaceable and simple-to-install module.



## Energy efficiency

The drive provides features such as an energy optimizer and energy efficiency information that help you monitor and save the energy used in the processes.

## Speed feedback interfaces

Optional speed feedback modules support HTL, TTL and absolute encoders as well as resolver feedback.



## Drive-to-drive link

Allows fast communication between drives including master-follower configurations without any additional hardware.



## Wall-mounted drives, ACS880-01

The all-compatible drives architecture is designed to provide customers across industries and applications with unprecedented levels of compatibility and flexibility. The wall-mounted ACS880-01 drives can be customized to the precise needs of industries such as oil and gas, mining, metals, chemicals, cement, power plants, material handling, pulp and paper, sawmills and marine. They are designed to control a wide range of applications such as cranes, extruders, winches, winders, conveyors, mixers, compressors, pumps and fans.



### Intuitive human-machine interface

Intuitive, high-contrast and high-resolution display enabling easy navigation in multiple languages.



### Startup and maintenance tool

PC tool for drive startup, configuration and daily use and process tuning. PC tool is connected to the drive via Ethernet or USB interface.



### Communication with all major automation networks

Fieldbus adapters enable connectivity with all major automation networks.



### Input/output extensions

In addition to the standard interfaces the drive has two built-in slots for additional input/output extension modules.

### Flexible product configurations

Drives are built-to-order with a wide range of options such as EMC filters, braking options and different enclosure variants.



## Human all-compatible



The new drives share easy-to-use interfaces saving you time during drive commissioning and maintenance. When you have learned it once, you can use it with all the drives in our all-compatible drives portfolio.

The new control panel supports over 20 languages. The new PC tool provides extensive drive monitoring capabilities and quick access to the drive settings. Integrated and certified safety features provide safety for machine operators.



## Process all-compatible

The drives are compatible with all kinds of processes. They control virtually any type of AC motor, provide extensive input/output connectivity and support all major fieldbus protocols. The drives cover a wide voltage and power range. Control performance is scalable from basic to demanding applications delivered by direct torque control (DTC). The flexibility and scalability of the drives enable one drive platform to control virtually any application or process, making your drive selection easy.



## Environment all-compatible

There is an increased demand for reducing industries' impact on the environment. Our drives can help you reduce energy consumption in a wide range of applications. The new drives have an energy optimizer feature that ensures maximum torque per ampere, reducing energy drawn from the supply. The built-in energy efficiency calculators help you to analyze and optimize processes. We can help you to investigate the energy saving potential of selected applications with our six-step energy appraisal. Our services expand through the life cycle of the drive and help you maintain energy efficiency from installation and commissioning to drive replacement.







## Business all-compatible



The new all-compatible drives are not just equipment but part of your business strategy. Providing better control over your processes, the new drives equal lower energy consumption, improved productivity, flexibility and ease of use. In addition to drives we offer a wide range of products and services to support your business. With offices in over 90 countries and a global technical partner network, we are in a good position to offer technical advice and local support, worldwide.

# How to select a drive

Many of the features for ACS880 drives are built in as standard making selection easy. A wide options offering is available to optimize the drive for different requirements. To choose the right drive for your application, please refer to the ratings table on page 11. The selected drive has a unique type designation,

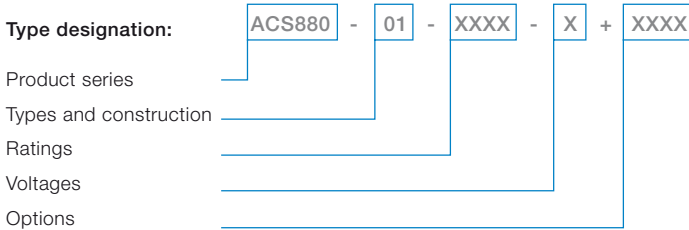

which identifies the drive by construction, power and voltage range. The options are added to the type designation with a “plus” code. Build up your own ordering code using the type designation key below or contact your local ABB drives sales office and let them know what you want.



## Technical data

| Mains connection  |  |
|---|--|
| <b>Voltage and power range</b>  | 3-phase, $U_{NS}$ = 380 to 415 V, +10/-15%<br>3-phase, $U_{NS}$ = 380 to 500 V, +10/-15%<br>0.55 to 250 kW   |
| <b>Frequency</b>  | 50 / 60 Hz $\pm$ 5%  |
| <b>Power factor</b>   | $\cos\phi_1$ = 0.98 (fundamental)<br>$\cos\phi$ = 0.93 to 0.95 (total)   |
| <b>Efficiency (at nominal power)</b>  | 98%  |
| Motor connection  |  |
| <b>Voltage</b>  | 3-phase output voltage 0 to $U_1$  |
| <b>Frequency</b>  | 0 to $\pm$ 500 Hz*   |
| <b>Motor control</b>  | Direct torque control (DTC)  |
| <b>Torque control:</b>  | Torque step rise time:<br>Open loop <5 ms with nominal torque<br>Closed loop <5 ms with nominal torque<br>Non-linearity:<br>Open loop $\pm$ 4% with nominal torque<br>Closed loop $\pm$ 3% with nominal torque             |
| <b>Speed control:</b>   | Static accuracy:<br>Open loop 10% of motor slip<br>Closed loop 0.01% of nominal speed<br>Dynamic accuracy:<br>Open loop 0.3 to 0.4% seconds with 100% torque step<br>Closed loop 0.1 to 0.2% seconds with 100% torque step |
| Product compliance  |  |
| <ul style="list-style-type: none"> <li>- CE</li> <li>- Low Voltage Directive 2006/95/EC</li> <li>- Machinery Directive 2006/42/EC</li> <li>- EMC Directive 2004/108/EC</li> <li>- Quality assurance system ISO 9001 and Environmental system ISO 14001</li> <li>- RoHS</li> <li>- Pending: UL, cUL 508A or 508C and CSA C22.2 NO.14-95, C-Tick, GOST R</li> </ul> |  |
| EMC according to EN 61800-3 (2004)  |  |
| Categories C3 and C2 with internal option   |  |

| Environmental limits              |   |
|-----------------------------------|---|
| <b>Ambient temperature</b>        | Transport -40 to +70 °C<br>Storage -40 to +70 °C  |
| <b>Operation</b>                  | Air-cooled -15 to +55 °C, no frost allowed<br>+40 to +55 °C with derating of 1% / 1 °C  |
| <b>Cooling method</b>             | Air-cooled Dry clean air  |
| <b>Altitude</b>                   | 0 to 1,000 m Without derating<br>1,000 to 4,000 m With derating of 1% / 100 m   |
| <b>Relative humidity</b>          | 5 to 95%, no condensation allowed   |
| <b>Degree of protection</b>       | IP21 Standard<br>IP55 Option  |
| <b>Paint color</b>                | RAL 9017, RAL 9002  |
| <b>Contamination levels</b>       | No conductive dust allowed  |
| <b>Storage</b>                    | IEC 60721-3-1, Class 1C2 (chemical gases), Class 1S2 (solid particles)  |
| <b>Transportation</b>             | IEC 60721-3-2, Class 2C2 (chemical gases), Class 2S2 (solid particles)  |
| <b>Operation</b>                  | IEC 60721-3-3, Class 3C2 (chemical gases), Class 3S2 (solid particles)  |
| <b>Functional safety Standard</b> | Safe torque-off (STO according EN 61800-5-2)<br>IEC 61508: SIL 3, IEC 61511: SIL3, IEC 62061: SILCL 3, EN ISO 13849-1: PL e   |
| <b>Internal safety option</b>     | Safe stop 1 (SS1), safely-limited speed (SLS), safe stop emergency (SSE), safe brake control, (SBC) and safe maximum speed (SMS)<br>IEC 61508: SIL 2, IEC 61511: SIL2, IEC 62061: SILCL 2, EN ISO 13849-1: PL d |

C = chemically active substances

S = mechanically active substances

\* For higher output frequencies please contact your local ABB office

# Ratings, types and voltages

$U_N = 400\text{ V}$  (range 380 to 415 V). The power ratings are valid at nominal voltage 400 V.

| Nominal ratings |                |             | Light-overload use |                | Heavy-duty use |                | Noise level | Heat dissipation | Air flow          | Type designation | Frame size |
|-----------------|----------------|-------------|--------------------|----------------|----------------|----------------|-------------|------------------|-------------------|------------------|------------|
| $I_N$<br>A      | $I_{max}$<br>A | $P_N$<br>kW | $I_{Ld}$<br>A      | $P_{Ld}$<br>kW | $I_{Hd}$<br>A  | $P_{Hd}$<br>kW | dBA         | W                | m <sup>3</sup> /h |                  |            |
| 2.4             | 3.1            | 0.75        | 2.3                | 0.75           | 1.8            | 0.55           | 46          | 30               | 44                | ACS880-01-02A4-3 | R1         |
| 3.3             | 4.1            | 1.1         | 3.1                | 1.1            | 2.4            | 0.75           | 46          | 40               | 44                | ACS880-01-03A3-3 | R1         |
| 4               | 5.6            | 1.5         | 3.8                | 1.5            | 3.3            | 1.1            | 46          | 52               | 44                | ACS880-01-04A0-3 | R1         |
| 5.6             | 6.8            | 2.2         | 5.3                | 2.2            | 4              | 1.5            | 46          | 73               | 44                | ACS880-01-05A6-3 | R1         |
| 7.2             | 9.5            | 3           | 6.8                | 3              | 5.6            | 2.2            | 46          | 94               | 44                | ACS880-01-07A2-3 | R1         |
| 9.4             | 12.2           | 4           | 8.9                | 4              | 7.2            | 3              | 46          | 122              | 44                | ACS880-01-09A4-3 | R1         |
| 12.6            | 16             | 5.5         | 12                 | 5.5            | 9.4            | 4              | 46          | 172              | 44                | ACS880-01-12A6-3 | R1         |
| 17              | 21             | 7.5         | 16                 | 7.5            | 12.6           | 5.5            | 51          | 232              | 88                | ACS880-01-017A-3 | R2         |
| 25              | 29             | 11          | 24                 | 11             | 17             | 7.5            | 51          | 337              | 88                | ACS880-01-025A-3 | R2         |
| 32              | 42             | 15          | 30                 | 15             | 25             | 11             | 57          | 457              | 134               | ACS880-01-032A-3 | R3         |
| 38              | 54             | 18.5        | 36                 | 18.5           | 32             | 15             | 57          | 562              | 134               | ACS880-01-038A-3 | R3         |
| 45              | 64             | 22          | 43                 | 22             | 38             | 18.5           | 62          | 667              | 200               | ACS880-01-045A-3 | R4         |
| 61              | 76             | 30          | 58                 | 30             | 45             | 22             | 62          | 907              | 200               | ACS880-01-061A-3 | R4         |
| 72              | 104            | 37          | 68                 | 37             | 61             | 30             | 62          | 1117             | 280               | ACS880-01-072A-3 | R5         |
| 87              | 122            | 45          | 83                 | 45             | 72             | 37             | 62          | 1120             | 280               | ACS880-01-087A-3 | R5         |
| 105             | 148            | 55          | 100                | 55             | 87             | 45             | 67          | 1295             | 435               | ACS880-01-105A-3 | R6         |
| 145             | 178            | 75          | 138                | 75             | 105            | 55             | 67          | 1440             | 435               | ACS880-01-145A-3 | R6         |
| 169             | 247            | 90          | 161                | 90             | 145            | 75             | 67          | 1940             | 450               | ACS880-01-169A-3 | R7         |
| 206             | 287            | 110         | 196                | 110            | 169            | 90             | 67          | 2310             | 450               | ACS880-01-206A-3 | R7         |
| 246             | 350            | 132         | 234                | 132            | 206            | 110            | 65          | 3300             | 550               | ACS880-01-246A-3 | R8         |
| 293             | 418            | 160         | 278                | 160            | 246            | 132            | 65          | 3900             | 550               | ACS880-01-293A-3 | R8         |
| 363             | 498            | 200         | 345                | 200            | 293            | 160            | 68          | 4200             | 1150              | ACS880-01-363A-3 | R9         |
| 430             | 617            | 250         | 428                | 250            | 363            | 200            | 68          | 4800             | 1150              | ACS880-01-430A-3 | R9         |

$U_N = 500\text{ V}$  (range 380 to 500 V). The power ratings are valid at nominal voltage 500 V.

| Nominal ratings |                |             | Light-overload use |                | Heavy-duty use |                | Noise level | Heat dissipation | Air flow          | Type designation | Frame size |
|-----------------|----------------|-------------|--------------------|----------------|----------------|----------------|-------------|------------------|-------------------|------------------|------------|
| $I_N$<br>A      | $I_{max}$<br>A | $P_N$<br>kW | $I_{Ld}$<br>A      | $P_{Ld}$<br>kW | $I_{Hd}$<br>A  | $P_{Hd}$<br>kW | dBA         | W                | m <sup>3</sup> /h |                  |            |
| 2.1             | 3.1            | 0.75        | 2.0                | 0.75           | 1.6            | 0.55           | 46          | 30               | 44                | ACS880-01-02A1-5 | R1         |
| 3               | 4.1            | 1.1         | 2.8                | 1.1            | 2.1            | 0.75           | 46          | 40               | 44                | ACS880-01-03A0-5 | R1         |
| 3.4             | 5.6            | 1.5         | 3.2                | 1.5            | 3              | 1.1            | 46          | 52               | 44                | ACS880-01-03A4-5 | R1         |
| 4.8             | 6.8            | 2.2         | 4.6                | 2.2            | 3.4            | 1.5            | 46          | 73               | 44                | ACS880-01-04A8-5 | R1         |
| 5.2             | 9.5            | 3           | 4.9                | 3              | 4              | 2.2            | 46          | 94               | 44                | ACS880-01-05A2-5 | R1         |
| 7.6             | 12.2           | 4           | 7.2                | 4              | 5.2            | 3              | 46          | 122              | 44                | ACS880-01-07A6-5 | R1         |
| 11              | 16             | 5.5         | 10.4               | 5.5            | 7.6            | 4              | 46          | 172              | 44                | ACS880-01-11A0-5 | R1         |
| 14              | 21             | 7.5         | 13                 | 7.5            | 11             | 5.5            | 51          | 232              | 88                | ACS880-01-014A-5 | R2         |
| 21              | 29             | 11          | 19                 | 11             | 14             | 7.5            | 51          | 337              | 88                | ACS880-01-021A-5 | R2         |
| 27              | 42             | 15          | 26                 | 15             | 21             | 11             | 57          | 457              | 134               | ACS880-01-027A-5 | R3         |
| 34              | 54             | 18.5        | 32                 | 18.5           | 27             | 15             | 57          | 562              | 134               | ACS880-01-034A-5 | R3         |
| 40              | 64             | 22          | 38                 | 22             | 34             | 18.5           | 62          | 667              | 200               | ACS880-01-040A-5 | R4         |
| 52              | 76             | 30          | 49                 | 30             | 40             | 22             | 62          | 907              | 200               | ACS880-01-052A-5 | R4         |
| 65              | 104            | 37          | 62                 | 37             | 52             | 30             | 62          | 1117             | 280               | ACS880-01-065A-5 | R5         |
| 77              | 122            | 45          | 73                 | 45             | 65             | 37             | 62          | 1120             | 280               | ACS880-01-077A-5 | R5         |
| 96              | 148            | 55          | 91                 | 55             | 77             | 45             | 67          | 1295             | 435               | ACS880-01-096A-5 | R6         |
| 124             | 178            | 75          | 118                | 75             | 96             | 55             | 67          | 1440             | 435               | ACS880-01-124A-5 | R6         |
| 156             | 247            | 90          | 148                | 90             | 124            | 75             | 67          | 1940             | 450               | ACS880-01-156A-5 | R7         |
| 180             | 287            | 110         | 171                | 110            | 156            | 90             | 67          | 2310             | 450               | ACS880-01-180A-5 | R7         |
| 240             | 350            | 132         | 228                | 132            | 180            | 110            | 65          | 3300             | 550               | ACS880-01-240A-5 | R8         |
| 260             | 418            | 160         | 247                | 160            | 240            | 132            | 65          | 3900             | 550               | ACS880-01-260A-5 | R8         |
| 361             | 542            | 200         | 343                | 200            | 260            | 160            | 68          | 4800             | 1150              | ACS880-01-361A-5 | R9         |
| 414             | 617            | 250         | 393                | 250            | 361            | 200            | 68          | 6000             | 1150              | ACS880-01-414A-5 | R9         |

## Nominal ratings

$I_N$  Rated current available continuously without overloadability at 40 °C.

$P_N$  Typical motor power in no-overload use.

$I_{MAX}$  Maximum output current. Available for 10 seconds at start, then as long as allowed by drive temperature.

## Light-overload use

$I_{Ld}$  Continuous current allowing 110%  $I_{Ld}$  for 1 min / 5 min at 40 °C.

$P_{Ld}$  Typical motor power in light-overload use.

## Heavy-duty use

$I_{Hd}$  Continuous current allowing 150%  $I_{Hd}$  for 1 min / 5 min at 40 °C.

$P_{Hd}$  Typical motor power in heavy-duty use.

The current ratings depend on the supply voltage.

The ratings apply at 40 °C ambient temperature. At higher temperatures (up to 55 °C) the derating is 1% / 1 °C.

| Frame size | Height 1 (mm) | Height 2 (mm) | Width (mm) | Depth (mm) | Weight (kg) |
|------------|---------------|---------------|------------|------------|-------------|
| R1         | 405           | 370           | 155        | 227        | 6           |
| R2         | 405           | 370           | 155        | 250        | 8           |
| R3         | 471           | 420           | 172        | 262        | 10          |
| R4         | 573           | 490           | 203        | 275        | 18.5        |
| R5         | 730           | 596           | 203        | 274        | 23          |
| R6         | 726           | 548           | 252        | 357        | 45          |
| R7         | 880           | 623           | 284        | 365        | 55          |
| R8         | 963           | 700           | 300        | 386        | 70          |
| R9         | 955           | 700           | 380        | 414        | 98          |

H1 = Height with cable entry box

H2 = Height without cable entry box

Width and depth with cable entry box

# Standard interface and extensions for comprehensive connectivity

The ACS880-01 offers a wide range of standard interfaces. In addition the drive has three option slots that can be used for extensions including fieldbus adapter modules, input/output

extension modules, feedback modules and a safety functions module.

| Control connections                         | Description   |
|---|---|
| 2 analog inputs (XAI)                       | Current input: -20 to 20 mA, $R_{in}$ : 100 ohm<br>Voltage input: -10 to 10 V, $R_{in}$ : 200 kohm<br>Resolution: 11 bit + sign bit   |
| 2 analog outputs (XAO)                      | 0 to 20 mA, $R_{load} < 500$ ohm<br>Frequency range: 0 to 300 Hz<br>Resolution: 11 bit + sign bit   |
| 6 digital inputs (XDI)                      | Input type: NPN/PNP (DI1 to DI5), NPN (DI6)<br>DI6 (XDI:6) can alternatively be used as an input for 1 to 3 PTC thermistors.  |
| Digital input interlock (DIIL)              | Input type: NPN/PNP   |
| 2 digital inputs/outputs (XDIO)             | As input:<br>24 V logic levels:<br>"0" < 5 V, "1" > 15 V<br>$R_{in}$ : 2.0 kohm<br>Filtering: 0.25 ms<br>As output:<br>Total output current from 24 V DC is limited to 200 mA<br>Can be set as pulse train input and output |
| 3 relay outputs XRO1, XRO2, XRO3            | 250 V AC / 30 V DC, 2 A   |
| Safe torque-off (STO)                       | For the drive to start, both connections must be closed   |
| Drive-to-drive link (XD2D)                  | Physical layer: EIA-485   |
| Built-in Modbus                             | EIA-485   |
| Assistant control panel/ PC tool connection | Connector: RJ-45  |



## Default input/output connection diagram

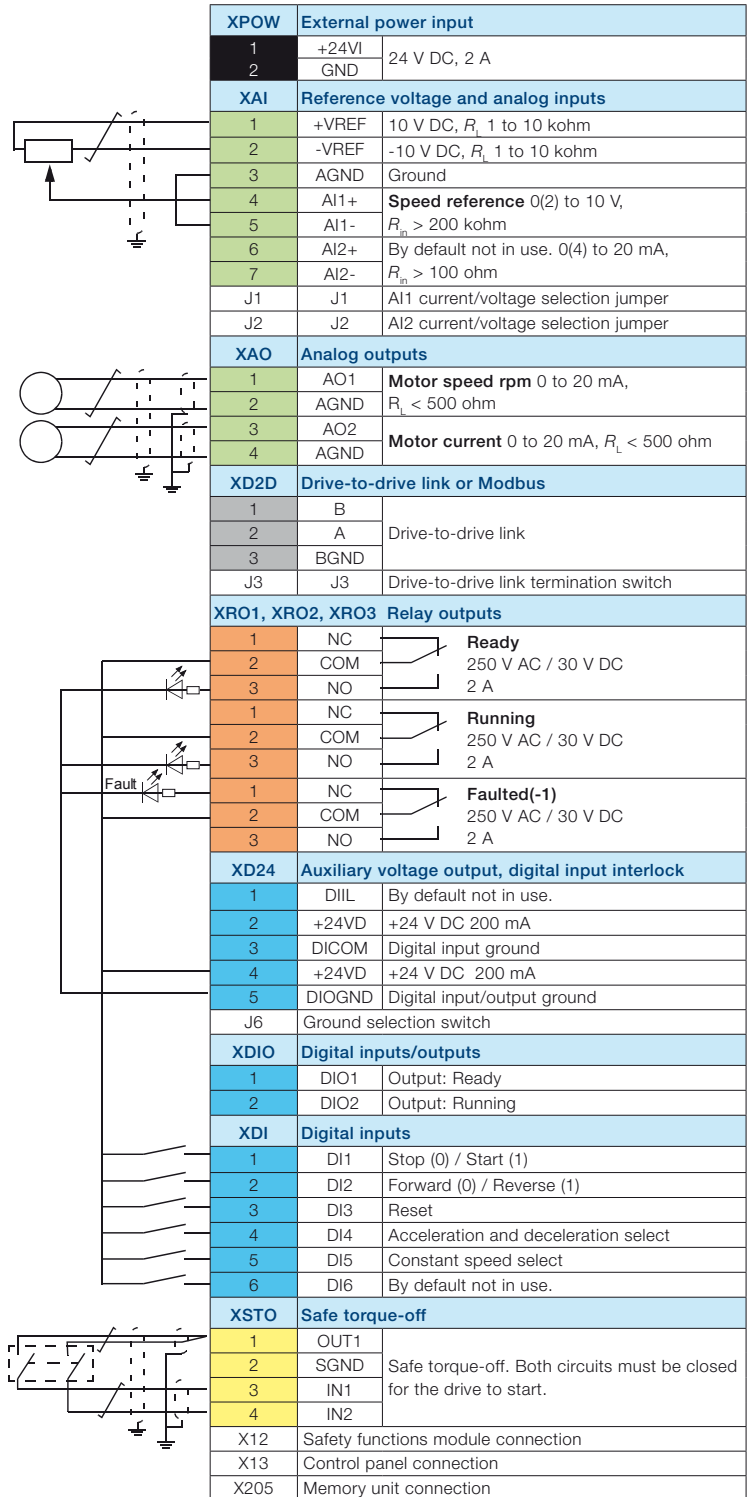

# Standard software for scalable control and functionality

The same standard software, primary control program, is used across the whole ACS880 series. Features such as built-in preprogrammed application macros save time during configuration and drive commissioning. The application macros help set parameters for various functionalities, including:

- Basic setup for input/output control and fieldbus adapter control
- Hand/auto control for local and remote operation
- PID control for closed loop processes
- Sequential control for repetitive cycles
- Torque control
- Four user defined sets, for own parameter settings

The drives are equipped with direct torque control (DTC), ABB's signature motor control platform which supports motors such as induction motors, permanent magnet synchronous motors and servo motors. DTC helps control the motor from standstill to maximum torque and speed without the necessity of position sensors or encoders. DTC allows high overloadability, gives high starting torque and reduces stress on mechanics.

The drives come with built-in energy efficiency information that helps the user fine-tune processes to ensure optimum energy use. The energy optimizer mode ensures the maximum torque per ampere, reducing energy drawn from the supply. The load profile feature collects drive values with three loggers: two amplitude loggers and one peak value logger. Calculators provide essential energy efficiency information: used and saved electrical energy, CO<sub>2</sub> reduction and money saved.

Additional software features include:

- Adaptive programming
- Automatic reset
- Automatic start
- Access levels
- Constant speeds
- Critical speeds and frequencies
- DC hold
- DC magnetizing
- Diagnostics
- Flux braking
- Mechanical brake control
- Drive-to-drive link for master-follower control
- Power loss ride-through
- Process PID control with trim function
- Programmable inputs and outputs
- Programmable and pre-programmed protection functions
- Speed controller with auto tuning
- Startup assistants
- Scalar control with IR compensation
- User selectable acceleration and deceleration ramps
- User adjustable load supervision/limitation
- Variable slope

## Removable memory unit

The removable memory unit stores the standard software that includes user settings, parameter settings and motor data. Situated on the control unit, the memory unit can easily be removed for maintenance, update or replacement purposes. This common type of memory unit is used throughout the ACS880 series.



# Intuitive human-machine interface

The assistant control panel features intuitive use and easy navigation. High resolution display enables visual guidance. The panel saves on commissioning and learning time by means of different assistants, making the drive simple to set up and use.

It is possible to organize parameters in different ways and store essential parameters for different configurations for any specialized application needed. The menus and messages are customizable for specific terminology, so each application can be set up and configured to its optimum performance. This makes the drive easier to use with information that is

familiar to users. With the panel's text editor the user can also add information, customize text and label the drive. Powerful backup and restore functions are supported as well as different language versions. The help key provides context sensitive guidance. Faults or warnings can be resolved quickly since the help key provides troubleshooting instructions.

One control panel can be connected to several drives simultaneously using the panel network feature. The user can also select the drive to operate in the panel network. The PC tool can be easily connected to the drive through the USB connector on the control panel.



# PC tool for easy startup and maintenance

The Drive composer PC tool offers fast and harmonized setup, commissioning and monitoring for the whole drives portfolio. The free entry version provides startup and maintenance capabilities, while the professional version of the tool provides additional features such as custom parameter windows, control diagrams of the drive's configuration and safety settings.

The Drive composer tool is connected to the drive using an Ethernet connection or through the USB connection on the control panel. With one mouse click all drive information such as parameter lists, faults, backup and event lists are gathered into a support diagnostics file. This provides faster fault tracking, shortens downtime and minimizes operational and maintenance costs.

## Drive composer pro

Drive composer pro provides both basic functionality, including parameter settings, downloading and uploading files and searching parameters, and advanced features such as graphical control diagrams and various displays. The control diagrams save users from browsing long lists of parameters and help to set the drive's logic quickly and easily. The tool has fast monitoring capabilities of multiple signals from several drives in a network. Full backup and restore functions are also included. Safety settings can be configured with Drive composer pro.



# Integrated safety for simplified configuration

Integrated safety reduces the need for external safety components, simplifying the configuration and reducing installation space. In the ACS880 the safety functionality is a built-in feature. The ACS880 comes with safe torque-off as standard. Optional safety functions include safe stop 1, safe stop emergency, safely-limited speed, safe brake control and safe maximum speed. The drives' functional safety complies with the requirements of the European Union Machinery Directive 2006/42/EC.

## Safe torque-off as standard

Safe torque-off (STO) is used for prevention of unexpected startup (with such hardware as a key lock switch) or other stopping-related functions enabling safe machine maintenance and operation. With safe torque-off the drive will not provide a rotational field, thereby preventing the motor from generating a torque on the shaft. This function corresponds to an uncontrolled stop in accordance with stop category 0 of EN 60204-1.

## The safety functions module

The safety functions module FSO-11 comes with self diagnostic functionality and a range of safety functions that meet current safety requirements and standards in one compact module. Compared to using external safety components, the FSO-11 provides a cost-efficient solution packed into a single safety functions module to ensure safe drive operation. The FSO-11 is easy to mount in the drive.

Commissioning and configuration is done through the Drive composer pro PC tool. The safety functions module supports the following safety functions (which at least achieve SIL2 or PL d safety level (Cat. 3)):

- Safe stop 1 (SS1) initiates motor deceleration (eg, emergency stop, stop category 1), monitors deceleration and automatically activates the safe torque-off. When stopped this function corresponds to a controlled stop in accordance with EN 60204-1.
- Safely-limited speed (SLS) prevents the motor from exceeding the specified safe speed.
- Safe brake control (SBC) provides a safe output for controlling the motor's external (mechanical) brakes.
- Safe maximum speed (SMS) monitors the drive output frequency to ensure it does not exceed the set. This function is set to be continuously active, to provide protection for eg, structural maximum motor frequency.
- Safe stop emergency (SSE) can be configured to, upon request, either activate STO instantly (category 0 stop), or first initiate motor deceleration and then when motor is stopped activate the STO (category 1 stop).





# Flexible connectivity to automation networks

Our fieldbus adapter modules enable communication between drives, systems, devices and software. Our industrial drives are compatible with a wide range of fieldbus protocols.

The plug-in fieldbus adapter module can easily be mounted inside the drive. Other benefits include reduced wiring costs when compared with traditional input/output connections. Fieldbus systems are also less complex than conventional systems resulting in less overall maintenance.

## Multiple fieldbus connections for flexible control

ACS880 supports two fieldbus connections simultaneously. The user has flexibility of choice for control modes, and the possibility for redundant fieldbus adapters using the same protocol.

## Drive monitoring

A set of drive parameters and/or actual signals, such as torque, speed, current, etc., can be selected for cyclic data transfer providing fast data access.

## Drive diagnostics

Accurate and reliable diagnostic information can be obtained through the alarm, limit and fault words.

## Drive parameter handling

The Ethernet fieldbus adapter module allows users to build an Ethernet network for drive monitoring and diagnostic and parameter handling purposes.

## Cabling

Substituting the large amount of conventional drive control cabling and wiring with a single cable reduces costs and increases system reliability and flexibility.

## Design

The use of fieldbus control reduces engineering time at installation due to the modular structure of the hardware and software and the simplicity of the connections to the drives.

## Commissioning and assembly

The modular machine configuration allows pre-commissioning of single machine sections and provides easy and fast assembly of the complete installation.

## Universal communication with ABB fieldbus adapters

The ACS880 supports the following fieldbus protocols:

### Fieldbus adapter modules

| Option    | Option code | Fieldbus protocol                     |
|-----------|-------------|---------------------------------------|
| FPBA-01 * | +K454       | PROFIBUS DP, DPV0/DPV1                |
| FCAN-01 * | +K457       | CANopen®                              |
| FDNA-01 * | +K451       | DeviceNet™                            |
| FENA-11 * | +K473       | EtherNet/IP™, Modbus TCP, PROFINET IO |
| FECA-01 * | +K469       | EtherCAT®                             |

\*For further details please contact your local ABB sales office.



# Input/output extension modules for increased connectivity

Standard input and output can be extended by using optional analog and digital input/output extension modules. The modules are easily installed in the extension slots located on the drive.

## Analog and digital input/output extension modules

| Option | Option code | Connections                          |
|--------|-------------|--------------------------------------|
| FIO-01 | +L501       | 4 x DI/O, 2 x RO                     |
| FIO-11 | +L500       | 3 x AI (mA/V), 1 x AO (mA), 2 x DI/O |



# Speed feedback interfaces for precise process control

ACS880 drives can be connected to various feedback devices, such as HTL pulse encoder, TTL pulse encoder, absolute encoder and resolver. The optional feedback module

is installed in the option slot on the drive. It is possible to use two feedback modules at the same time, either of the same type or different type.

## Feedback interface modules

| Option | Option code | Connections   |
|--------|-------------|---|
| FEN-01 | +L517       | 2 inputs (TTL incremental encoder), 1 output                  |
| FEN-11 | +L518       | 2 inputs (SinCos absolute, TTL incremental encoder), 1 output |
| FEN-21 | +L516       | 2 inputs (Resolver, TTL incremental encoder), 1 output        |
| FEN-31 | +L502       | 1 input (HTL incremental encoder), 1 output                   |



# Brake options

## Brake chopper

The brake chopper is built in as standard for the ACS880-01 frame sizes R1 to R4. For the other frames a brake chopper is a selectable internal option. Braking control is integrated into the ACS880-01. It controls braking, supervises system status and detects failures such as brake resistor and resistor cable short-circuits, chopper short-circuit, and calculated resistor overtemperature.

## Brake resistor

The brake resistors are separately available for ACS880-01. Resistors other than the standard resistors may be used providing the specified resistance value is not decreased, and the heat dissipation capacity of the resistor is sufficient for the drive application. No separate fuses in the brake circuit are required if the conditions for eg. the mains cable is protected with fuses and no mains cable/fuse overrating takes place.



# EMC – electromagnetic compatibility

Each ACS880 model can be equipped with a built-in filter to reduce high frequency emissions.

## EMC standards

The EMC product standard (EN 61800-3 (2004)) covers the specific EMC requirements stated for drives (tested with motor and cable) within the EU. EMC standards such as EN55011, or EN 61000-6-3/4, are applicable to industrial and domestic equipment and systems including components inside the drive. Drive units complying with the requirements of EN 61800-3 are compliant with comparable categories in EN 55011 and EN 61000-6-3/4, but not necessarily vice versa. EN 55011 and EN 61000-6-3/4 do not specify cable

length or require a motor to be connected as a load. The emission limits are comparable to EMC standards according to the following table below.

## 1<sup>st</sup> environment versus 2<sup>nd</sup> environment

1<sup>st</sup> environment includes domestic premises. It also includes establishments directly connected without an intermediate transformer to a low-voltage power supply network that supplies buildings used for domestic purposes.

2<sup>nd</sup> environment includes all establishments other than those directly connected to a low voltage power supply network that supplies buildings used for domestic purposes.

## EMC standards

| EMC according to EN 61800-3 (2004) product standard    | EN 61800-3 product standard | EN 55011, product family standard for industrial, scientific and medical (ISM) equipment | EN 61000-6-4, generic emission standard for industrial environments | EN 61000-6-3, generic emission standard for residential, commercial and light-industrial environment |
|--|-----------------------------|--|---|--|
| 1 <sup>st</sup> environment, unrestricted distribution | Category C1                 | Group 1, Class B   | Not applicable  | Applicable   |
| 1 <sup>st</sup> environment, restricted distribution   | Category C2                 | Group 1, Class A   | Applicable  | Not applicable   |
| 2 <sup>nd</sup> environment, unrestricted distribution | Category C3                 | Group 2, Class A   | Not applicable  | Not applicable   |
| 2 <sup>nd</sup> environment, restricted distribution   | Category C4                 | Not applicable   | Not applicable  | Not applicable   |

## Selecting an EMC filter

The following table gives the correct filter selection.

| Type      | Voltage    | Frame sizes | 1 <sup>st</sup> environment, restricted distribution, C2, grounded network (TN)<br>Option code | 2 <sup>nd</sup> environment, C3 grounded network (TN)<br>Option code | 2 <sup>nd</sup> environment, C3, ungrounded network (IT)<br>Option code |
|-----------|------------|-------------|--|--|---|
| ACS880-01 | 380 to 500 | R1 to R9    | +E202  | +E200  | +E210<br>(R6 to R9 frame size)  |

# du/dt filters

du/dt filtering suppresses inverter output voltage spikes and rapid voltage changes that stress motor insulation. Additionally, du/dt filtering reduces capacitive leakage currents and high frequency emission of the motor cable as well as high frequency losses and bearing currents in the motor. The need for du/dt filtering depends on the motor insulation. For information on the construction of the motor insulation, consult the manufacturer.

If the motor does not fulfil the following requirements, the lifetime of the motor might decrease. Insulated N-end (nondriven end) bearings and / or common mode filters are also required for motor bearing currents with motors bigger than 100 kW. For more information please see the ACS880 hardware manuals.

How to select a filter according to the motor. Please see below:



NOCH0016-62



NOCH0016-60



NOCH0016-65



FOCH0610-70

## Filter selection table for ACS880

| Motor type | Nominal AC supply voltage | Requirements for        |  |
|------------|---------------------------|-------------------------|--|
|            |                           | Motor insulation system | ABB du/dt and common mode filters, insulated N-end motor bearings  |
|            |                           |                         | $P_N < 100 \text{ kW}$ and<br>frame size < IEC 315   |
|            |                           |                         | $100 \text{ kW} \leq P_N < 350 \text{ kW}$ or<br>$\text{IEC } 315 \leq \text{frame size} < \text{IEC } 400$      |
|            |                           |                         | $P_N < 134 \text{ hp}$ and<br>frame size < NEMA 500  |
|            |                           |                         | $134 \text{ hp} \leq P_N < 469 \text{ hp}$ or<br>$\text{NEMA } 500 \leq \text{frame size} \leq \text{NEMA } 580$ |

### ABB motors

|                                     |  |  |  |             |
|-------------------------------------|--|--|--|-------------|
| Random-wound<br>M2__, M3__ and M4__ | $U_N \leq 500 \text{ V}$   | Standard                                 | -  | + N         |
|                                     | $500 \text{ V} < U_N \leq 600 \text{ V}$   | Standard                                 | + du/dt                                    | + du/dt + N |
|                                     |  | or<br>Reinforced                         | -  | + N         |
|                                     | $600 \text{ V} < U_N \leq 690 \text{ V}$<br>(cable length $\leq 150 \text{ m}$ ) | Reinforced                               | + du/dt                                    | + du/dt + N |
| Form-wound<br>HX__ and AM__         | $380 \text{ V} < U_N \leq 690 \text{ V}$   | Standard                                 | n.a.                                       | + N + CMF   |
| Old* form-wound<br>HX__ and modular | $380 \text{ V} < U_N \leq 690 \text{ V}$   | Check with the motor manufacturer        | + du/dt with voltages over 500 V + N + CMF |             |
| Random-wound<br>HX__ and AM__**     | $0 \text{ V} < U_N \leq 500 \text{ V}$   | Enmelled wire with<br>fiber glass taping | + N + CMF                                  |             |
|                                     | $500 \text{ V} < U_N \leq 690 \text{ V}$   |  | + du/dt + N + CMF                          |             |
| HDP                                 | Consult the motor manufacturer.  |  |  |             |

\* manufactured before 1.1.1998

\*\* For motors manufactured before 1.1.1998, check for additional instructions with the motor manufacturer.

| Motor type | Nominal AC supply voltage | Requirements for                         |  |   |
|------------|---------------------------|--|--|---|
|            |                           | Motor insulation system                  | ABB du/dt and common mode filters, insulated N-end motor bearings          |   |
|            |                           |  | $P_N < 100$ kW and frame size < IEC 315                                    | $100$ kW $\leq P_N < 350$ kW or IEC 315 $\leq$ frame size < IEC 400 |
|            |                           | $P_N < 134$ hp and frame size < NEMA 500 | $134$ hp $\leq P_N < 469$ hp or NEMA 500 $\leq$ frame size $\leq$ NEMA 580 |   |

#### Non-ABB motors

|                             |                            |   |         |                              |
|-----------------------------|----------------------------|---|---------|------------------------------|
| Random-wound and form-wound | $U_N \leq 420$ V           | Standard<br>$\dot{U}_{LL} = 1300$ V                                     | -       | + N or CMF                   |
|                             | $420$ V < $U_N \leq 500$ V | Standard<br>$\dot{U}_{LL} = 1300$ V                                     | + du/dt | + du/dt + N or + du/dt + CMF |
|                             |                            | or<br>Reinforced:<br>$\dot{U}_{LL} = 1600$ V, 0.2 microsecond rise time | -       | + N or CMF                   |
|                             | $500$ V < $U_N \leq 600$ V | Reinforced:<br>$\dot{U}_{LL} = 1600$ V                                  | + du/dt | + du/dt + N or + du/dt + CMF |
|                             |                            | or<br>Reinforced:<br>$\dot{U}_{LL} = 1800$ V                            | -       | + N or CMF                   |
|                             | $600$ V < $U_N \leq 690$ V | Reinforced:<br>$\dot{U}_{LL} = 1800$ V                                  | + du/dt | + du/dt + N                  |
|                             |                            | Reinforced:<br>$\dot{U}_{LL} = 2000$ V, 0.3 microsecond rise time       | -       | + N or CMF                   |

#### The abbreviations used in the table are defined below

| Abbr.          | Definition  |
|----------------|---|
| $U_N$          | Nominal AC line voltage.  |
| $\dot{U}_{LL}$ | Peak line-to-line voltage at motor terminals which the motor insulation must withstand.         |
| $P_N$          | Motor nominal power.  |
| du/dt          | du/dt filter at the output of the drive. Available from ABB as an optional add-on kit.          |
| CMF            | Common mode filter. Available from ABB as an optional add-on kit.                               |
| N              | N-end bearing; insulated motor non-drive end bearing.   |
| n.a.           | Motors of this power range are not available as standard units. Consult the motor manufacturer. |

#### External du/dt filters for ACS880-01

| ACS880 |        | du/dt filter type (3 filters included in kits marked *) |             |             |                   |                |             |                   |             |             |             |             |             |             |             |             |             |   |
|--------|--------|---|-------------|-------------|-------------------|----------------|-------------|-------------------|-------------|-------------|-------------|-------------|-------------|-------------|-------------|-------------|-------------|---|
|        |        | Unprotected (IP00)                                      |             |             | Protected to IP22 |                |             | Protected to IP54 |             |             |             |             |             |             |             |             |             |   |
|        |        | NOCH0016-60   | NOCH0030-60 | NOCH0070-60 | NOCH0120-60 *)    | NOCH0260-60 *) | FOCH0260-70 | FOCH0320-50       | FOCH0610-70 | NOCH0016-62 | NOCH0030-62 | NOCH0070-62 | NOCH0120-62 | NOCH0016-65 | NOCH0030-65 | NOCH0070-65 | NOCH0120-65 |   |
| 400 V  | 500 V  |   |             |             |                   |                |             |                   |             |             |             |             |             |             |             |             |             |   |
| 02A4-3 | 02A1-5 | 1   |             |             |                   |                |             |                   |             | 1           |             |             |             | 1           |             |             |             |   |
| 03A3-3 | 03A0-5 | 1   |             |             |                   |                |             |                   |             | 1           |             |             |             | 1           |             |             |             |   |
| 04A0-3 | 03A4-5 | 1   |             |             |                   |                |             |                   |             | 1           |             |             |             | 1           |             |             |             |   |
| 05A6-3 | 04A8-5 | 1   |             |             |                   |                |             |                   |             | 1           |             |             |             | 1           |             |             |             |   |
| 07A2-3 | 05A2-5 | 1   |             |             |                   |                |             |                   |             | 1           |             |             |             | 1           |             |             |             |   |
| 09A4-3 | 07A6-5 | 1   |             |             |                   |                |             |                   |             | 1           |             |             |             | 1           |             |             |             |   |
| 12A6-3 | 11A0-5 | 1   |             |             |                   |                |             |                   |             | 1           |             |             |             | 1           |             |             |             |   |
| 017A-3 | 014A-5 | 1   |             |             |                   |                |             |                   |             | 1           |             |             |             | 1           |             |             |             |   |
|        | 021A-5 | 1   |             |             |                   |                |             |                   |             | 1           |             |             |             | 1           |             |             |             |   |
| 025A-3 | 027A-5 |   | 1           |             |                   |                |             |                   |             |             | 1           |             |             |             |             | 1           |             |   |
|        |        |   | 1           |             |                   |                |             |                   |             |             | 1           |             |             |             |             | 1           |             |   |
| 032A-3 | 034A-5 |   |             | 1           |                   |                |             |                   |             |             |             | 1           |             |             |             |             | 1           |   |
| 038A-3 | 040A-5 |   |             | 1           |                   |                |             |                   |             |             |             | 1           |             |             |             |             | 1           |   |
| 045A-3 | 052A-5 |   |             | 1           |                   |                |             |                   |             |             |             | 1           |             |             |             |             | 1           |   |
| 061A-3 | 065A-5 |   |             | 1           |                   |                |             |                   |             |             |             | 1           |             |             |             |             | 1           |   |
| 072A-3 | 077A-5 |   |             | 1           |                   |                |             |                   |             |             |             | 1           |             |             |             |             | 1           |   |
| 087A-3 | 096A-5 |   |             |             | 1                 |                |             |                   |             |             |             |             | 1           |             |             |             |             | 1 |
| 105A-3 | 124A-5 |   |             |             | 1                 |                |             |                   |             |             |             |             | 1           |             |             |             |             | 1 |
| 145A-3 | 156A-5 |   |             |             | 1                 |                |             |                   |             |             |             |             |             |             |             |             |             |   |
| 169A-3 | 180A-5 |   |             |             |                   | 1              |             |                   |             |             |             |             |             |             |             |             |             |   |
| 206A-3 | 240A-5 |   |             |             |                   |                | 1           |                   |             |             |             |             |             |             |             |             |             |   |
| 246A-3 | 260A-5 |   |             |             |                   |                | 1           |                   |             |             |             |             |             |             |             |             |             |   |
| 293A-3 |        |   |             |             |                   |                | 1           |                   |             |             |             |             |             |             |             |             |             |   |
| 363A-3 | 361A-5 |   |             |             |                   |                |             | 1                 |             |             |             |             |             |             |             |             |             |   |
| 430A-3 | 414A-5 |   |             |             |                   |                |             | 1                 |             |             |             |             |             |             |             |             |             |   |

#### Dimensions and weights of the du/dt filters

| du/dt filter   | Height mm | Width mm | Depth mm | Weight kg |
|----------------|-----------|----------|----------|-----------|
| NOCH0016-60    | 195       | 140      | 115      | 2.4       |
| NOCH0016-62/65 | 323       | 199      | 154      | 6         |
| NOCH0030-60    | 215       | 165      | 130      | 4.7       |
| NOCH0030-62/65 | 348       | 249      | 172      | 9         |
| NOCH0070-60    | 261       | 180      | 150      | 9.5       |
| NOCH0070-62/65 | 433       | 279      | 202      | 15.5      |
| NOCH0120-60**  | 200       | 154      | 106      | 7         |
| NOCH0120-62/65 | 765       | 308      | 256      | 45        |
| NOCH0260-60**  | 383       | 185      | 111      | 12        |
| FOCH0260-70    | 382       | 340      | 254      | 47        |
| FOCH0320-50    | 662       | 319      | 293      | 65        |
| FOCH0610-70    | 662       | 319      | 293      | 65        |

\*\* 3 filters included, dimensions apply for one filter.

# Expertise at every stage of the value chain

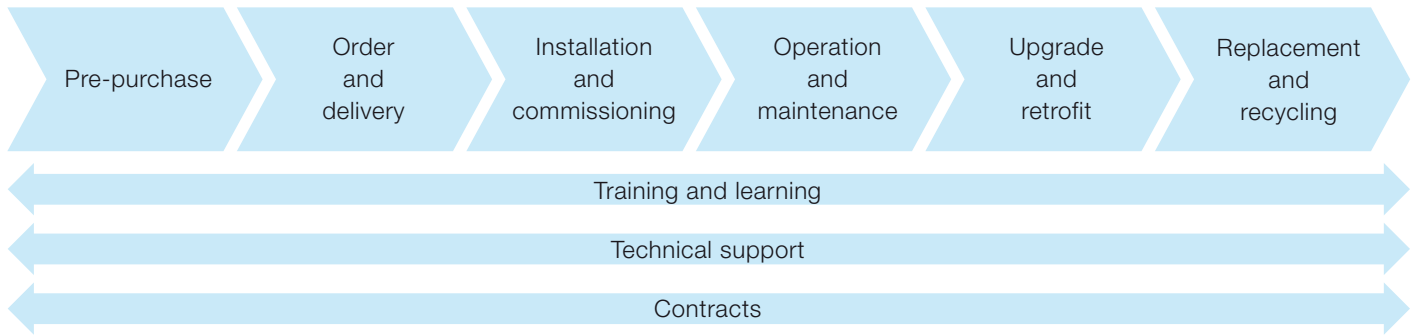

The services offered for ABB low voltage drives span the entire value chain, from the moment a customer makes the first enquiry through to disposal and recycling of the drive. Throughout the value chain, ABB provides training and learning, technical support and contracts. All of this is supported by one of the most extensive global drive sales and service networks.

## Pre-purchase

ABB provides a range of services that help guide the customers to the right products for their applications. Examples of services include correct drive selection and dimensioning, energy appraisal, harmonic survey and EMC assessment.

## Order and delivery

Orders can be placed through any ABB office or through ABB's channel partners. Placing and tracking of orders can be done online.

ABB's sales and services network offers timely deliveries including express delivery.

## Installation and commissioning

While many customers have the resources to undertake installation and commissioning on their own, ABB and its channel partners are available to advise or undertake the entire drive installation and commissioning.

## Operation and maintenance

Through remote monitoring, ABB can guide the customer through a fast and efficient fault-finding procedure as well as analyze the operation of the drive and the customer's process. From maintenance assessment to preventive maintenance and reconditioning of drives, ABB has all the options covered to keep its customers' processes operational.

Should corrective maintenance of drives be needed, ABB offers on-site and workshop repair, fully backed up by the most extensive spare holding.

## Upgrade and retrofit

An existing ABB drive can often be upgraded to the latest software or hardware to improve the performance of the application.

Existing processes can be economically modernized by retrofitting the latest drive technology to mechanical control equipment, such as inlet guide vanes or dampers or older generations of drives.

Instead of replacing an entire drive or drive system, it is often more economical to modernize the old installation by reusing all relevant parts of the original equipment and purchasing new where necessary.

## Replacement and recycling

ABB can advise on the best replacement drive while ensuring that the existing drive is disposed in a way that meets all local environmental regulations.

## Entire value chain services

The main services available throughout the value chain include:

- Training and learning – ABB offers product and application training in classrooms and on the Internet.
- Technical support – At each stage of the value chain, an ABB expert is available to offer advice to keep the customer's process or plant operational.
- Contracts – Drive care contracts and other types of agreements, from individual services through to complete drive care covering all repairs and even drive replacements, are available.

Customers that register their drives with ABB can get six months drive care contract for free. To qualify, contact your local ABB office.

# Secure uptime throughout the drive life cycle

ABB follows a four-phase model for managing the life cycles of its drives. The life cycle phases are active, classic, limited and obsolete. The availability of individual services varies according to the drive life cycle phase.

Examples of individual services are drive selection and dimensioning, installation and commissioning, preventive and corrective maintenance, remote monitoring and intelligent diagnostics, technical support, upgrade and retrofit, replacement and recycling plus training and learning.

In the active phase the drive is in serial production. The drive, with complete life cycle services, is available for purchase.

In the classic phase, the serial production of the drive has ended. The drive, with complete life cycle services, is available for plant extensions.

In the limited phase, the drive is no longer available. The life cycle services are limited. Spare parts as well as maintenance and repair services are available as long as materials can be obtained.

In the obsolete phase, the drive is not available. ABB cannot guarantee availability of services for technical reasons or within reasonable cost.

ABB defines individual services and their duration for every drive at each phase of its life cycle. Services are identical in the active and classic phases.

To ensure the availability of complete life cycle services, ABB recommends that a drive is kept in the active or classic phase by upgrading, retrofitting or replacing.

In the classic phase ABB carries out an annual review for each drive life cycle plan. Should any changes to the availability or duration of the services be necessary, ABB gives a life cycle announcement indicating eventual change of life cycle phase and/or any change in the duration of services.

In the limited phase, ABB issues a life cycle phase change announcement, half a year prior to shifting the product into the obsolete phase.

## Maximizing return on investment

The life cycle management model provides customers with a transparent method for managing their investment in drives. In each phase, customers clearly see what life cycle services are available, and more importantly, what services are not available. Decisions on upgrading, retrofitting or replacing drives can be made with confidence.

## ABB drive life cycle management model

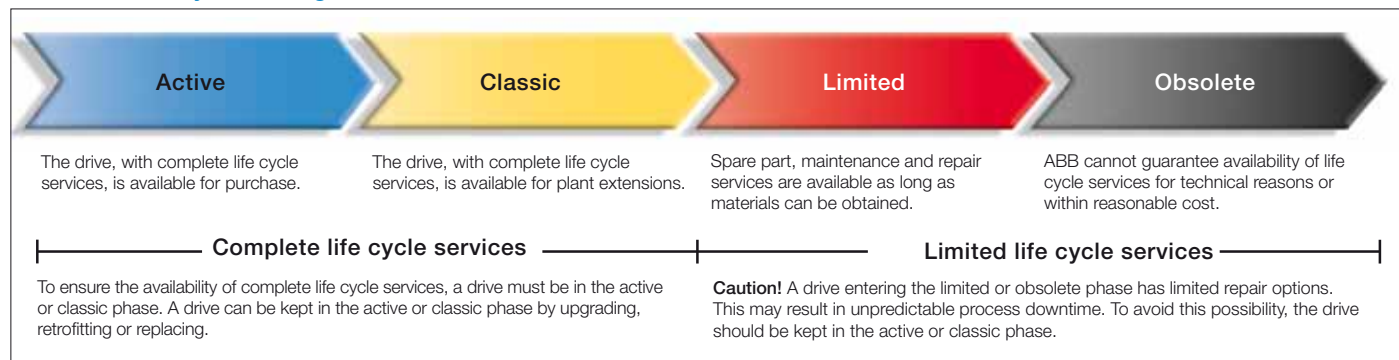

# Contact us

For more information contact your local  
ABB representative or visit:

[www.abb.com/drives](http://www.abb.com/drives)

[www.abb.com/drivespartners](http://www.abb.com/drivespartners)

© Copyright 2011 ABB. All rights reserved.  
Specifications subject to change without notice.



441 024  
Printed matter

3AUA0000098111 REV D EN 28.10.2011